

# The GLC.

Make the best of every ground.



Mercedes-Benz



# The GLC. Ever higher. Further ahead.

Encounter every drive on a whole new level: with the GLC. Progressive and athletic, yet virtually silent and astonishingly efficient – so much is possible with one of the most advanced SUVs in its class. Get on board: an interior that is as exquisite and spacious, awaits you. The GLC. Make the best of every ground.

In its element every kilometre of the way.

- 18 | Engines
- 19 | 9G-TRONIC
- 20 | DYNAMIC SELECT
- 21 | Off-Road Mode
- 22 | Edition 1 Exterior
- 28 | Edition 1 Interior
- 33 | Infotainment
- 34 | Active Parking Assist
- 35 | Safety and assistance systems
- 36 | Genuine accessories
- 42 | Upholstery, Trim and Alloy
- 43 | Paintwork
- 44 | Dimensions
- 45 | Technical data
- 46 | Service
- 48 | Dealer Network

## SUV. These three letters have never sounded so good.

Radiate effortless superiority and power without appearing pushy. Stipulate the direction with pride and confidence, whilst knowing when to hold back. This is the fine art of contemporary luxury. And this is the design idiom of the GLC. The upright, highly expressive front and the three-dimensionally configured radiator grille lend it a progressive presence. On the side of the vehicle precise feature lines and muscular surfaces produce an inimitably Sensual Purity, a hallmark of the new Mercedes-Benz Design.



## Town. Country. And everywhere in between.

Make the best of every drive: five different drive programs can be selected via the DYNAMIC SELECT Controller on the centre console: Comfort, ECO, Individual, Sport and Sport+. They influence factors such as the drive system, the chassis and the steering. This means that the driving experience can be optimally adapted to individual requirements or to external conditions.





## Looking into the future.

The Intelligent Light System is standard with the GLC. The clearly defined contours and high-quality detailing with the three-dimensional design ensure that the vehicle has an unmistakable front view. The LEDs used are also much more durable and more efficient than conventional lights. A characteristic feature is what is known as the flare with the functions indicator, position light and daytime running lamps. The light follows the inside contours, ensuring a distinctive, very high-quality Mercedes-Benz Design during the daytime and at night.

## Knows only one direction: onwards.

### Crosswind Assist

Sudden gusts of wind can take a vehicle off course, especially at high speeds. In the GLC a standard-fit Crosswind Assist ensures quiet and stability. It is part of the Electronic Stability Program ESP® and it is active from a speed of 80 km/h when driving straight ahead and during slight cornering. Depending on the direction and the intensity of the crosswind meeting the car, it can influence the braking torques in an intelligent manner. The driver is supported through a brake actuation on one side of the car. The influence of the wind on the car is reduced to a minimum, whilst handling safety is maximised.



Life in the city.  
At its best by a distance.



Every type of ground is good grounds –  
for the GLC.







## Luxury: Up close and personal.

More radiance, more depth. More elegance and more appeal. Luxury is tangible with the new Mercedes-Benz GLC. The interior is designed to impress with its outstanding high quality feel and aesthetics. Whether you're off on a long journey with family or on a great adventure with friends, feel the luxury come alive every moment.

\*Please read the disclaimer.



\*Please read the disclaimer.

## What makes a car a Mercedes?

**Deep-rooted traditions:** in our case, it is innovative traditions that run deep. We have continually gone down previously uncharted avenues. Milestone by milestone. These ventures spawned the first vehicle with a crumple zone, the first ABS, the first diesel passenger car the first car. But rather than wallowing in the past, let us look to the future.

**Mercedes-Benz Intelligent Drive** – on the road to accident-free driving. We develop intelligent assistance systems which actively support the driver and noticeably relieve their workload. They monitor and analyse the vehicle's surroundings and handling characteristics – and warn the driver if they identify any critical situations. When necessary, some of the systems are able to intervene to take corrective action. Potential dangers are identified earlier than ever – and ever more frequently avoided as a result.

**4MATIC** – driven by new challenges, the vision of optimum traction led the Mercedes-Benz engineers to the International Motor Show in Frankfurt. That is where, in 1985, they unveiled 4MATIC, an innovative traction system working with state-of-the-art microelectronics and hydraulics. Just two years later it entered series production in the E-Class.

It has continued its triumphal advance ever since in virtually all model series. And on every terrain. 75 models are now out on the road with 4MATIC and it is tailor-made for each class. Comfortable and efficiently configured for the compact class, right through to extremely sporty for the Mercedes-AMG performance models. For more safety and an intensive driving experience in every single moment.

As you can see, we have major goals in our sights. And what could be better than seeing these aims achieved whilst on a long drive in a Mercedes?



# Energy needs change. And somebody to change it.

Efficient right from the start and endless power. An auditory experience, a soft, velvety way to deliver power, it's enough to give even the most experienced automotive enthusiast goose bumps. This Mercedes oozes self-assurance with every fibre of its being. It's hard to describe the ease with which even such a large SUV accelerates, how smoothly each command to the accelerator pedal is obeyed.

Two different drive variants, two different fuels, one common goal: to retain the uniquely high ride comfort of a Mercedes-Benz and at the same time to achieve astonishingly low consumption and emission values with incredible output and peak torque translates into almost inexhaustible reserves of power in virtually any driving situation.

## The Engine Range

---

### Diesel

---

GLC 220 d 4MATIC with an output of 125 kW (170 hp) and 400 Nm maximum torque

---

### Petrol

---

GLC 300 4MATIC with an output of 180 kW (245 hp) and 370 Nm maximum torque

---



\*Please read the disclaimer.

## 9G-TRONIC. The driving force masquerading as a transmission.

Featuring nine forward gears, this automatic transmission takes efficiency, comfort and dynamics to a completely new level. It is the world's first 9-speed automatic transmission with hydrodynamic torque converter in the premium segment. The wider gear spread allows a reduction in engine speed. Performance remains excellent, while ride comfort is enhanced and noise levels are reduced. Smaller gear ratio increments and faster gear changes lead to even greater responsiveness and agility. At the same time, 9G-TRONIC impresses with smooth, barely perceptible gear shifting like that of a continuously variable transmission. As 9G-TRONIC is able to skip individual gears, multiple downshifts are possible for fast and powerful sprints.

### **A Mercedes-Benz innovation**

The 9G-TRONIC is the world's first 9-speed automatic transmission with hydrodynamic torque converter in the premium segment. The innovative transmission, developed independently by Mercedes-Benz, offers more gears, more comfort and more economy. The nine forward gears with 9G-TRONIC allow a larger gear ratio range with even smaller jumps in engine speed between gears. This results in even faster, smoother and more efficient gear changes for enhanced driving comfort and reduced noise levels.

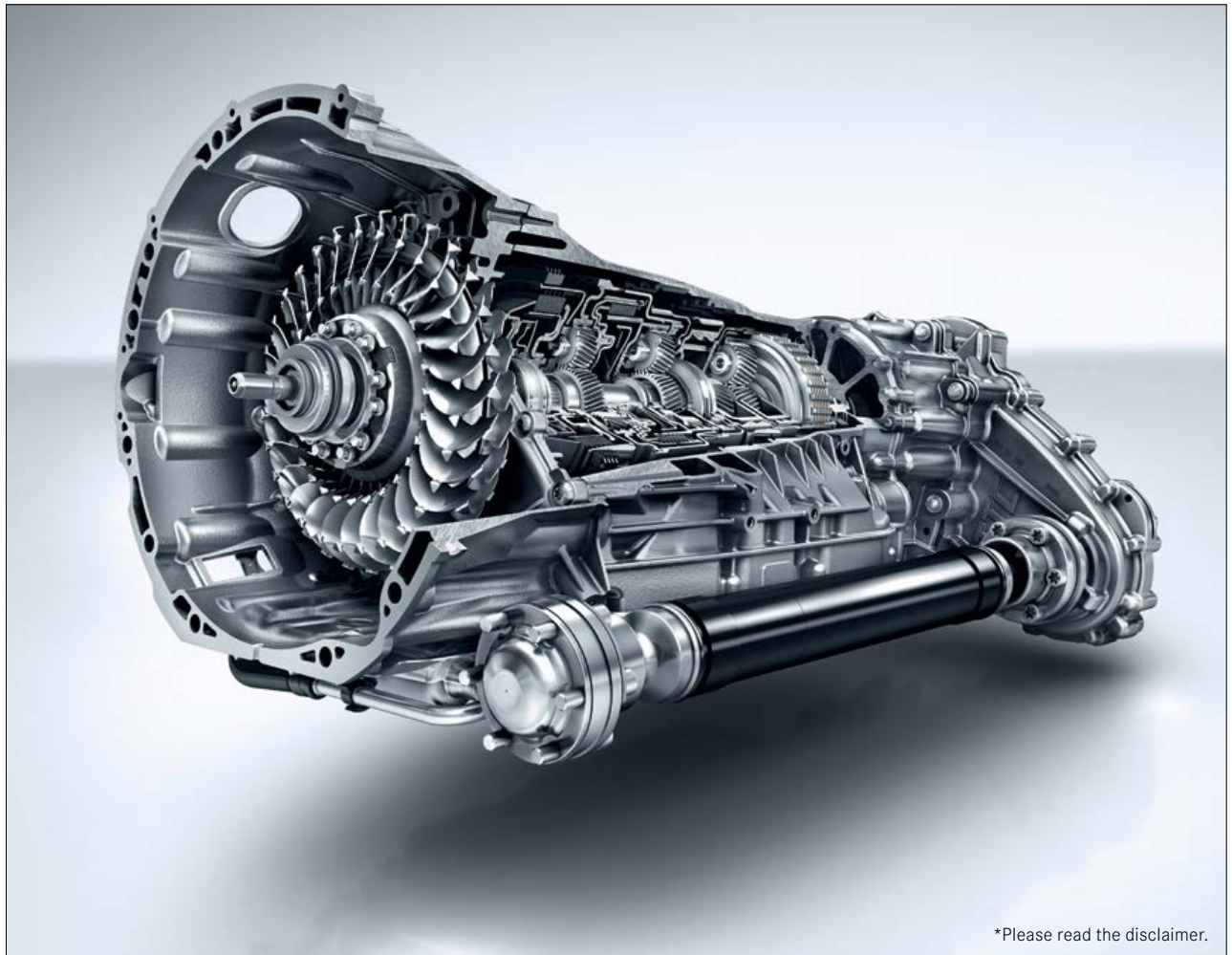

\*Please read the disclaimer.

## Emotions at the press of a button. DYNAMIC SELECT.

At the touch of the DYNAMIC SELECT feature in the centre console, drivers can choose between comfortable, sporty, particularly sporty and efficient driving styles, or their own individually defined style. To achieve this, parameters such as the engine, transmission, suspension and steering characteristics are adjusted according to the selected drive mode. The default setting is the well-balanced and fuel-efficient “Comfort” mode. The “Sport” drive mode offers added agility and dynamism thanks to its more progressive steering characteristic curve, sporty, spontaneous throttle response and modified shift points (with 9G-TRONIC). The element of sportiness can be enhanced even further by switching to the “Sport+” mode.



## For those special occasions: the Off-Road Mode

Whether on- or off-road, on easy or difficult terrain, on fast bends or slippery terrain – the Off-Road Mode makes it possible to adjust handling perfectly to the given situation, just by turning the DYNAMIC SELECT rotary switch. The characteristics of the ESP®, 4ETS, ASR, steering, ground clearance, air suspension and damping, for example, are automatically adjusted. The selected transmission mode is displayed in the instrument cluster and in the media display by means of an animation that depicts, for example, gradient and incline angle.



---

### Off-road Engineering package - for serious off-road adventures

---

OFF-ROAD suspension with higher ground clearance

---

Front bumper specially developed with higher angle of approach

---

Off-road light function - broader and brighter illumination of the terrain

---

3 Additional off-road driving modes: Off-road, Incline and Slippery

---

Additional activation of ABS, ESP® and ETS modes specially configured for off-road terrain

---

Safe, controlled downhill descents with Downhill Speed Regulation (DSR)

---

GEMTEX underguard protection

---



\*Please read the disclaimer.



\*Please read the disclaimer.

## Edition 1 Exterior – The elegance of a true athlete.

How it all began: Road presence is what strikes first with the OFF-ROAD design and equipment line. Combined with the legendary off-road expertise of Mercedes-Benz, these striking design elements evoke a sense of unabashed adventure and incandescent thrill. To further elevate its excitement, the Off-Road Engineering package is also available. It perfectly supplements genuine off-roading capability.

---

### EXTERIOR HIGHLIGHTS

---

Emotionally invigorating bodywork, with a long wheelbase and short overhangs

---

Radiator trim with 2 louvres and centrally positioned Mercedes star

---

Front bumper with large air intakes, simulated underide guard featuring bucket-tooth look, in silver chrome

---

LED headlamps, with Intelligent Light System (ILS)

---

45.7 cm (18-inch) 5-spoke light-alloy wheels

---

Electrically folding / automatically dimming exterior mirrors

---

Aluminium-look running boards with rubber studs

---

Exterior chrome package with roof rails, beltline trim strips and window weatherstrip in polished aluminium

---

Stainless steel tailpipe trim elements in the rear

---

“Edition 1” badge on the right and left wings

---



\*Please read the disclaimer.





\*Please read the disclaimer.

# Edition 1 Exterior – Standard Equipment

## Off-Road exterior line including Chrome package

The OFF-ROAD Exterior design and equipment line underscores the vehicle's SUV character with design features in chrome. The radiator trim boasts an integral Mercedes star and two louvres in matt iridium silver with chrome inserts. Other select highlights include the light-alloy wheels in 5-spoke design, the chrome-plated simulated underguard and the exhaust system with two visible, chrome-plated tailpipe trims and the anodised roof rails.

---

### Chrome Package

---

Radiator trim with integral Mercedes star and two louvres in matt iridium silver with chrome inserts

---

Simulated underguard front/rear in chrome

---

Roof railing in anodised aluminium, flush-fitted

---

Waistline trim strip in chrome

---

Window weatherstrip in chrome

---

Load compartment sill inside with metallic insert

---

Exhaust system with two visible stainless steel tailpipe trims, mounted in the bumper (with petrol engine), or decorative tailpipe trims (with diesel engines)

---



\*Please read the disclaimer.

# Edition 1 Exterior – Standard Equipment

## Intelligent Light System

The **Intelligent Light System** impresses sustainable with an unmistakable design, very low energy consumption and a long lifespan. But above all it offers even more vision and safety. When turning or cornering, the low-beam headlamps automatically adapt to the light and driving conditions. And the “Coming Home” function welcomes the driver with blue LED locator lighting when locking and unlocking the car via radio remote control key.

The **Intelligent Light System** in concrete terms: **1** | On rural roads the left-hand edge of the road is much better illuminated, in particular when the fog lamps are switched on. **2** | On motorways the visibility range is increased by up to 60 percent. **3** | The active light function enhances safety on bends. **4** | The cornering light increases safety when turning at crossroads due to better lateral illumination. The extended fog lamp function reduces dazzling of the vehicle’s driver due to light reflected by the fog.

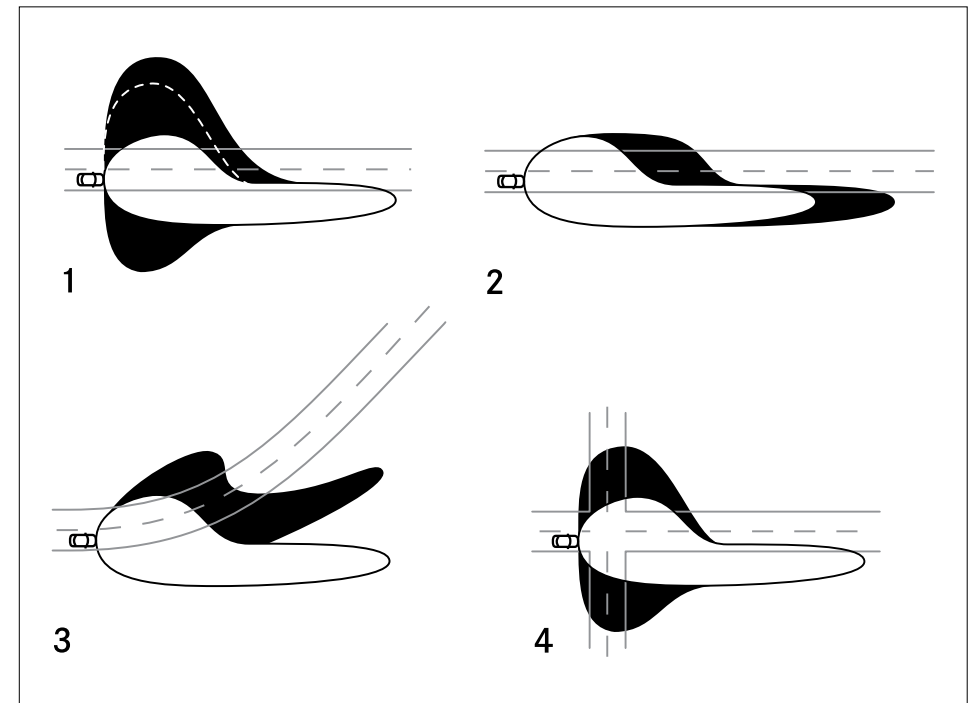

## Edition 1 Exterior – Standard Equipment

### Mirror package – more comfort, improved visibility

The exterior mirrors are electrically folding in order to protect the housing. For enhanced perception, the exterior mirror on the driver's side and the rear-view mirror are automatically and continuously self-dimming.



### Aluminium-look running boards with rubber studs

A real eye-catching feature are the aluminium-finish running boards. They are mounted on the side at the height of the side skirts, thus making it easier to get into the front and rear. Slip-resistant rubber studs ensure a firm foothold.





\*Please read the disclaimer.

## Edition 1 Interior - Excitingly luxurious.

The modernised interior and meticulous attention to detail enhances the luxurious overall impression given by the interior.

---

### Interior Highlights

---

Seats with exclusive seat upholstery layout and horizontal quilting in ARTICO man-made leather

---

ARTICO upholstery available in silk beige/espresso brown or black

---

4-way lumbar support for driver and front passenger

---

Electrically adjustable front seats with memory function

---

High-gloss brown line-structure lime wood trim

---

3-spoke multifunction steering wheel

---

Ambient lighting

---

THERMOTRONIC - 3 zone automatic climate control

---

Panoramic sliding sunroof

---

KEYLESS GO starting function

---



\*Please read the disclaimer.

# Edition 1 Interior - Standard Equipment

## EXCLUSIVE Interior - stylish exclusivity

The select appointments of this line create a trendsetting interior which re-interprets the meaning of luxury to exciting effect. These include seats with exclusive seat upholstery layout and horizontal quilting in ARTICO man-made leather in black or in silk beige/ espresso brown. The upper part of the dashboard and beltlines are in each case finished with ARTICO man-made leather depending on the appointments' colour and feature contrasting top-stitching to underscore the hand-finished nature of the high-quality interior. The 3-spoke multifunction steering wheel is trimmed in leather. Further highlights are created by the instrument display and large areas of trim in high-gloss brown linestructure lime wood.

## Ambient Lighting

Climb in and feel at home – with its pleasant, indirect light, the ambient lighting creates an unrivalled sense of well-being in the interior. Especially at night, it accentuates the contouring and high quality of the interior design, imparts a feeling of comfort and security by conjuring up an impression of spaciousness and reduces dazzle from oncoming traffic. Three different colours and five dimming levels are available for the desired lighting mood.



# Edition 1 Interior - Standard Equipment

## Automatic panoramic sliding sunroof

With its large glazed areas, this roof system ensures a particularly bright and welcoming ambience in the interior. It consists of a fixed panoramic glass rear section and an electrically operated glass front section sliding on outside rails with a meshed air deflector. In addition, two electric roller sunblinds provide shade for the occupants in strong sunlight. The panoramic sliding sunroof has numerous useful functions for a high level of travelling comfort.



## Driver and Passenger seats with memory

The electrically adjustable driver's seat enables convenient and individual adjustment of the seat position and head restraint. Adjustment is carried out intuitively via ergonomic switches on the door control panel. The settings can be stored for up to three people and recalled again at any time.



## THERMOTRONIC 3 zone climate control

The automatic climate control system with 3 climate zones and 3 airflow modes provides an individual feel-good climate on board. The driver and the front passenger are able to regulate temperature and air distribution independently of one another. Temperature and airflow for the rear can be adjusted separately.





# Edition 1 Interior - Standard Equipment

## Loading luxury

The load compartment is one of the most spacious in the segment. Open luggage compartment capacity behind the rear seat is 550 litres. Cargo bars behind the rear seat backrest are available to enlarge the luggage compartment by 30 litres. The larger dimensions of the load compartment opening and load compartment width make loading and unloading easier. This is where the switches for releasing the rear seat backrests and lowering the boot sill, as well as hooks and a 12V socket are positioned.

The Stowage Space package comprises a host of handy features for keeping everything neat and tidy, such as map pockets on the front seat backs or a collapsible box beneath the luggage compartment floor.



## EASY-PACK load compartment cover

The equipment protects the luggage from the sun and prying eyes. It comprises a retractable cover fitted behind the rear seats. The EASY-PACK load compartment cover can be removed at any time and stowed beneath the luggage compartment floor.



## EASY-PACK tailgate

The tailgate can be opened and closed at the touch of a button for more convenient loading and unloading of the load compartment. For safety reasons the automatic closing procedure can only be activated by pushing and holding the switch in the driver's door or using the ignition key. Manual opening is possible via the release handle on the tailgate.



## Sense and sensuality. The infotainment in the GLC.

### Multimedia in the GLC

The Audio 20 USB multimedia system with 17.8 cm (7-inch) media display is internet-capable and enables networking with mobile devices via Bluetooth®. User-friendly navigation, accurate map data and excellent route guidance – the Garmin® MAP PILOT transfers all the advantages of a Garmin® navigation system to the Audio 20 CD, with touchpad.



\*Please read the disclaimer.

# Shows you more of the world - Active Parking Assist

## Active Parking Assist: Parking. Nothing could be easier.

The **Active Parking Assist with PARKTRONIC** makes it easier to find a parking space and also to enter or leave parking spaces. When activated, it automatically steers the vehicle into perpendicular and parallel parking spaces, relieving the driver of the work of steering and braking. Reverse parking and manoeuvring is considerably easier and safer using the reversing camera. Protected by a flap, it automatically switches on when reverse gear is engaged and shows the driver the surroundings behind the vehicle with dynamic guide lines on the media display.

## Reversing Camera

Reverse parking and manoeuvring is made much easier and safer by the reversing camera. The camera shows the driver the area behind the vehicle on the Media Display. Dynamic guide lines provide clear orientation during driving manoeuvres. Depending on the steering angle, they visualise the trajectory, the vehicle's width and various distances from the rear end.



# The reassuring feeling of driving a Mercedes-Benz

We are the first automotive manufacturer worldwide to have developed an integral safety concept. aimed at avoiding accidents, ensuring ideal responses to dangers and lessening the consequences of accidents. For the occupants of a Mercedes and for all other road users, too.

## Safe driving

The **drowsiness detection system ATTENTION ASSIST** can enhance driving safety, in particular on long trips and during night-time driving. It can monitor the steering behaviour of the driver to recognise typical signs of drowsiness and severe loss of attention, and give a visual and acoustic warning of impending microsleep.

The **ADAPTIVE BRAKE** control system improves braking performance through intelligent intervention: in wet conditions, the brake discs are kept dry. The brake pads are applied automatically when the driver's foot is removed abruptly from the accelerator pedal. And on uphill slopes, the system is able to prevent the vehicle from rolling backwards.

## In the event of danger

The **PRE-SAFE® occupant protection system** is able to identify critical driving situations in advance and to initiate precautionary measures to protect the vehicle's occupants if an accident appears imminent. Such measures include reversible belt tensioning or automatic closing of open side windows, for example.

## In an accident

A comprehensive protection system can reduce the risk of injury for occupants and other road users. The car occupants can also be extensively protected by up to **seven airbags** including driver knee-bag.

## After an accident

Every Mercedes-Benz is optimally trained in first aid. If the worst comes to the worst, the engine can be switched off automatically and the central locking unlocked, plus the hazard warning lights and emergency interior lighting can be activated.

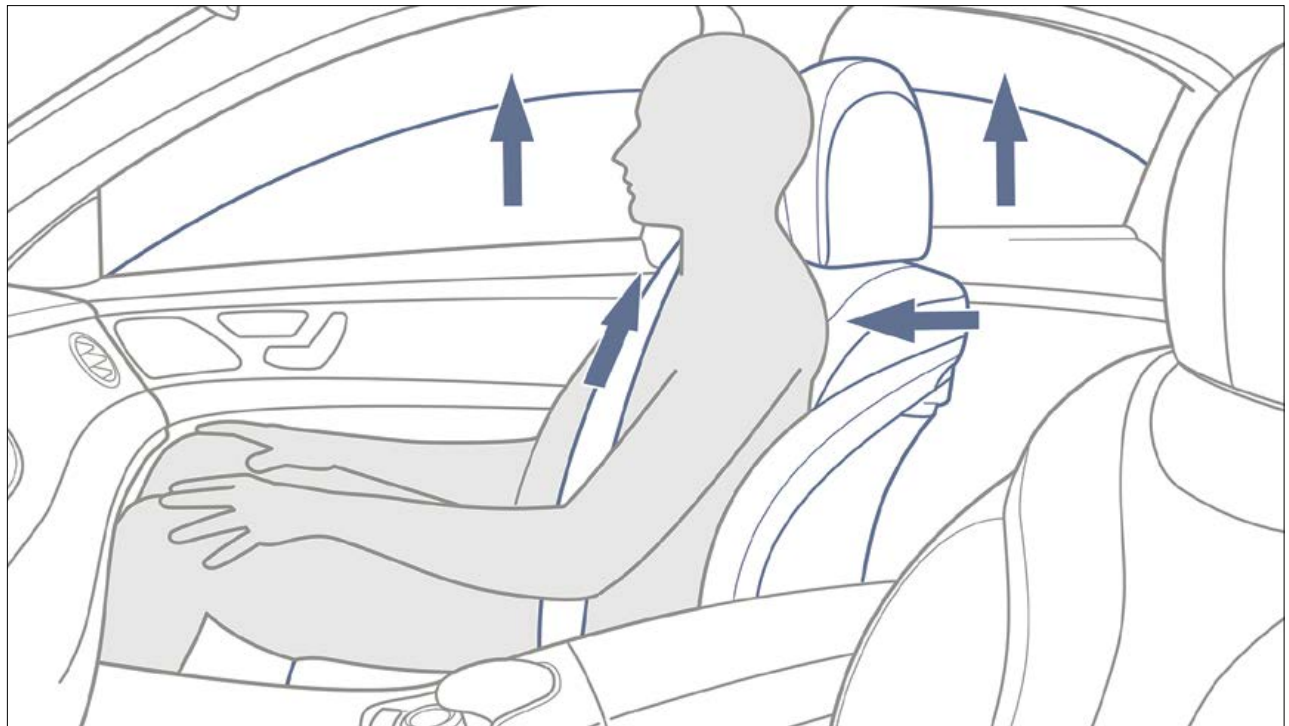

PRE-SAFE®

\*Please read the disclaimer.

## Genuine accessories

The range of genuine accessories is as extensive as the variety of routes you'll drive. Every accessory has been specifically developed for the GLC in accordance with the high Mercedes-Benz quality standards. Discover the entire range at [www.mercedes-benz-accessories.com](http://www.mercedes-benz-accessories.com)

Lockable roof-mounted bicycle rack for transporting two or three bicycles as required. Fully pre-assembled and ready to use. Extremely light weight as a result of aluminum/steel construction: 2.5 kgs.



The roof spoiler lends the car a more dynamic and sportier appearance, without restricting the field of vision in the rear-view mirror. A high-quality base coat makes the paint finish in the desired colour possible. No bores or entry in the vehicle documents are required.



The roof box matches the design of the GLC and is aerodynamic. Made of extremely durable material and lockable on both sides. It has a capacity of approx. 330 litres, the maximum payload is 50 kg (please bear in mind the permissible roof load of your car here).



\*Please read the disclaimer.

# Genuine accessories

## Styling

### Design side trim, 8-piece grained

Underline your Mercedes-Benz's sporty look: these Mercedes-Benz Sport Equipment trim elements add a dynamic finishing touch to your car's exterior. Perfect for combining with the separately available front trim.



### Roof spoiler, primed

A distinctive touch that gives the rear of the vehicle a more dynamic and sporty look. Does not affect field of vision in rear-view mirror. A high-quality primed finish allows the product to be painted in the desired colour.



### Rear trim strip chrome

High-sheen chromed rear trim strip. Coordinates with all of your vehicle's chrome trim parts.



### Trim front, 2-piece chrome, high-sheen chromed

High-sheen chromed trim elements in the air intakes add a distinctive accent for an individual look.



\*Please read the disclaimer.

# Genuine accessories

## Styling

### Exterior mirror housing, black

Black, high-gloss Mercedes-Benz Sport Equipment exterior mirror housings for enhanced aerodynamics and an individual, sporty and dynamic look.



### Door handle recess

An exclusive highlight: the refined, chrome-design door handle recesses lend the vehicle a polished, individual look. The stable, robust material is precision-tailored to the bodywork and protects the paintwork in the recess from scratches.



### Illuminated Star

Make the illuminated Mercedes star shine brightly. The star centred in the radiator grille of your Mercedes will light up courtesy of fibre optic and LED technology when the vehicle is locked and unlocked by remote control, and when a door or the tailgate is opened (only operates if engine is switched off).



\*Please read the disclaimer.

# Genuine accessories

## Cargo and Care

### Style and Travel equipment

The head restraint elements are simple to fit and remove. The modular system centres around a base support which can be combined with various products – a coat hanger, a universal hook or a folding table.

### Sports Pedal

For a sporty look – the pedal covers, in brushed stainless steel, add a sporty, high-quality touch to the interior. The genuine parts feature a non-slip rubber stud inlay and comply with Mercedes-Benz's safety.

### LED projectors

High-shine chromed rear trim strip. Coordinates with all of your vehicle's chrome trim parts.

### Mud flaps

The mud flaps protect the sides, rear and underbody of the vehicle from scratches and damage from loose chippings. They also help protect the following traffic from loose chippings, splash water and dirt. The Mud-Flaps are Precision tailored to the contours of the vehicle hence do not affect the vehicle's sporty looks. Mud Flaps are made of material that is extremely hard-wearing, durable and UV resistant.

### Floor mats

Floor mats have to undergo rigorous testing before they are deemed worthy of the star logo: durability, a fade resistant colour and a neutral odour – even after three winters of use.

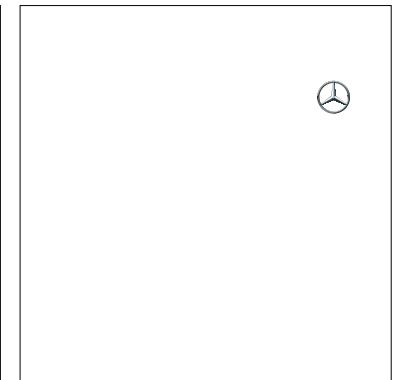

\*Please read the disclaimer.



# Genuine accessories

## Cargo and Care

### Boot Tub, Shallow

Mobility is the watchword of our times, and there is always plenty to transport on our travels. The shape of the tub, with its slightly raised edge, is optimally tailored to the load area. Very robust - made from impact-resistant, non-split polypropylene, the boot tub is ideal for foodstuffs and liquids. Structured surface prevents the load from sliding around and makes it easier to secure the optionally available stowage crate in place with a protected base.



### Boot Tub, Deep

Now take everything you want with the easy-clean boot tub. The deep edge (approx. 25 cm at the sides, 8 cm at the load edge) offers all-round protection. The overall shape is optimally tailored to the load area, ensuring that transporting liquids is not a problem. Even foodstuffs can be transported - the material is foodgrade and is easy to clean. The boot tub is light in weight, making it even easier to insert and remove.



### Concertina Load Sill Protector

Protects the rear of the car from scratches when you're loading the vehicle - and prevents dirt from the car from getting onto your clothes. Practical design - can be connected to shallow boot tub or reversible mat.



### Stowage Crate

A secure hold for items which are prone to tip over or slide around, e.g. shopping bags. Adjustable partitioning elements allow crate to be divided into maximum of four sections. Optimum functionality only in conjunction with shallow boot tub.



### Shopping Crate

A collapsible crate that is available in anthracite color. When not in use it can be folded and stowed away in the boot compartment. Features Mercedes-Benz logo and lettering.



\*Please read the disclaimer.

# Genuine accessories

## Alloys

Mercedes-Benz light-alloy wheels not only boost your vehicle's looks, they also offer the ultimate in safety. All wheels are precision-tailored to your vehicle in terms of load profile and dimensions. Before your light-alloy wheels are allowed to accompany you safely on your travels, they are subjected to an extensive development and testing programme. Each wheel design has to pass a variety of endurance tests, based on exacting Mercedes-Benz guidelines, all of which exceed statutory requirements.

The endurance tests include special test routines which simulate real challenges on the road and material tests in cutting-edge x-ray facilities. Only once all of the tests have been passed may the wheels be included in the range of genuine Mercedes-Benz light-alloy wheels. Add an individual touch to your vehicle with a tested and approved genuine Mercedes-Benz light-alloy wheel and head for the open road.



5-twin-spoke wheel, 45.7 cm (18 inch), matt himalaya grey, tyre size: 235/60/R18



6-spoke wheel, 48.3 cm (19 inch), black, tyre size: 235/55/R19



5-spoke wheel, 50.8 cm (20 inch), black, tyre size: 255/45/R20



5-twin-spoke wheel, 43.2 cm (17 inch), "Himalaya", grey, tyre size: 235/65/R17



5-spoke wheel, 48.3 cm (19 inch), black, tyre size: 235/55/R19

\*Please read the disclaimer.

# Upholstery, Trim and Alloy

---

## UPHOLSTERY

---

ARTICO man-made leather in black

---

ARTICO man-made leather in silk beige/espresso brown

---



---

## TRIM

---

High-gloss brown linestructure lime wood

---

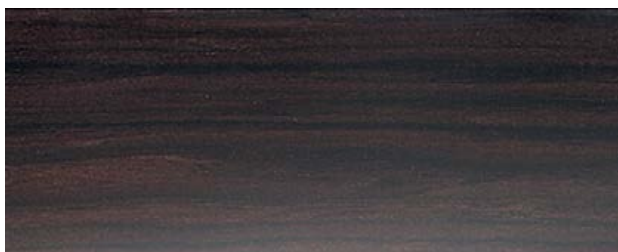

---

## ALLOY

---

5-spoke light-alloy wheels, painted tremolite grey and with a high-sheen finish, with 235/60 R18 tyres (option; part of the OFF-ROAD line)

---



\*Please read the disclaimer.

# Paintwork

---

## METALLIC PAINTS

---

Obsidian Black

---

Iridium Silver

---

Citrine Brown

---



---

## DESIGNO PAINTS

---

*designo* diamond white bright

---

*designo* hyacinth red metallic

---



\*Please read the disclaimer.

# Dimensions

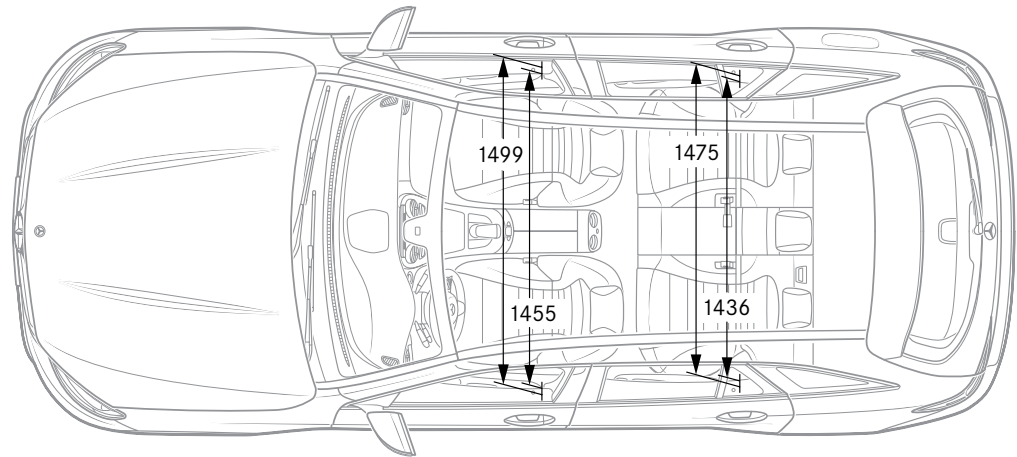
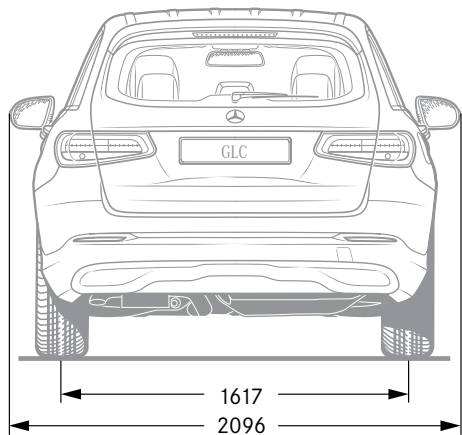
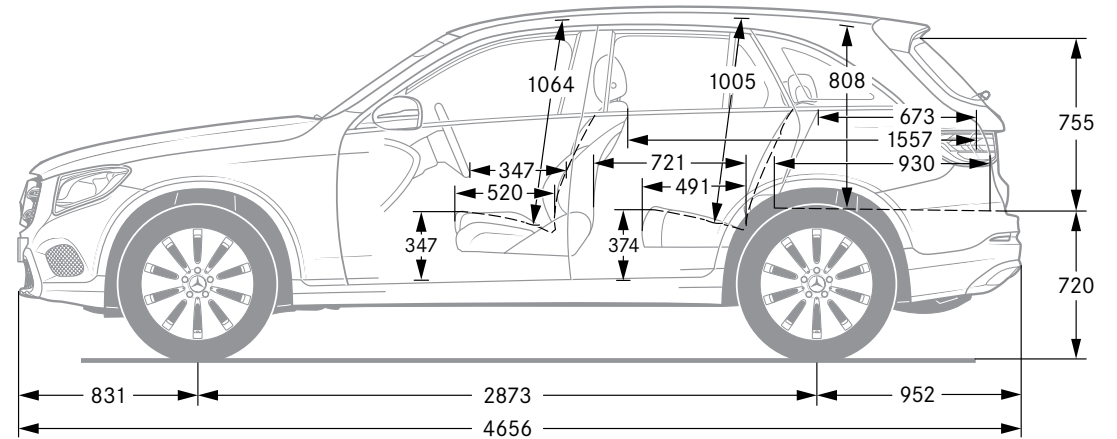
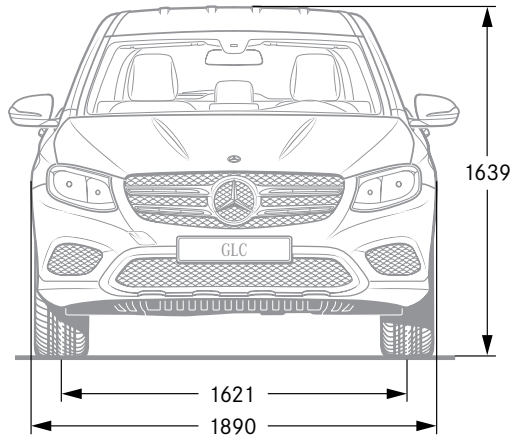

All dimensions in millimetres. The dimensions shown are mean values and apply to standard-specification, unladen vehicles.

## Technical data

	<b>GLC 300 4MATIC</b>	<b>GLC 220 d 4MATIC</b>
Displacement (bore X stroke) cc	1991	2143
Rated output kW (hp)	180 (245) @ 5500	125 (170) @ 3000-4200
Torque (Nm) @ rpm	370 @ 1300 - 4000	400 @ 1400 - 2800
Maximum speed (km/h)	222	210
Acceleration 0-100 (km/h) (s)	6.5	8.3
Tyre size	235/60 R18	235/60 R18
Maximum gross weight (Kg)	2400	2505
Kerb weight (Kg)	1871	1954
Transmission	9G-TRONIC	9G-TRONIC
Fuel type	Petrol	Diesel
Length (mm)	4656	4656
Width (mm)	1890	1890
Height (mm)	1639	1639
Wheelbase (mm)	2873	2873
Luggage capacity (litres)	550-1600	550-1600

\*Please read the disclaimer.

# Service

The luxurious experience of driving a Mercedes-Benz is converted into a fulfilling ownership experience with a range of exclusive services and special programmes.

## Cost of Ownership

There has been a paradigm shift in the buying preferences of Indian consumers over the years, even for the luxury products. The purchase decision not only dwells around cost of acquisition but also the total 'Cost of Ownership' (COO). Amongst the key components of COO in cars are the routine service jobs and the unplanned repair expenses post the warranty period. We are now offering highly-affordable Service Packages and Extended Warranty Programmes which are the most competitive packages in its class. All in all, we provide you with a controlled Cost of Ownership while you benefit from the legendary Mercedes-Benz service quality.



\*Please read the disclaimer.

## Experience complete peace of mind when you drive the Star

**STAR CARE** programme offers you peace of mind during the warranty period and beyond. While our cars are covered for warrantable repairs up to 3 years without any mileage limitations, as standard, you can also buy the STAR CARE Plus programme, offering 4<sup>th</sup> year extended warranty. Additionally, the programme enhances the resale value of your car.



Extended Warranty that guarantees complete peace of mind

**STAR EASE** Service Package gives you the freedom to relax behind the wheel and puts your mind at ease with its range of unique benefits such as defined cost of maintenance and priority handling. STAR EASE Comprehensive package covers essential jobs related to periodic service (viz. oil, filters, consumables, etc.) along with coverage for brake pads, brake discs, wiper blades and wheel alignment & balancing, for a contracted period. For further details on products and pricing, please contact your nearest Mercedes-Benz dealer.

**On-Road Assistance Programme** As part of our ongoing commitment to you, Mercedes-Benz On-Road Assistance is designed to enhance your overall Mercedes-Benz ownership experience by providing you with 24-hour On-Road Assistance. Mercedes-Benz is the only Luxury car manufacturer to offer round-the-clock On-Road Assistance for 3 years from purchase of vehicle as a standard offering. Peace of mind motoring – guaranteed.



The maintenance of your Star is just as peaceful as driving it



Always at your service

Conditions apply.



# India's Largest Luxury Car Network

It takes a keen sense of responsibility to provide the Best. Our large network is spread across the country in 40 cities with 83 outlets and is still growing. With world-class showrooms, state-of-the-art workshops and highly skilled personnel, experience the best wherever you go.



## DEALER CONTACT:

### NORTH & EAST:

**BHUBANESWAR:**  
Tristar Motors: 0-7852944100

**CHANDIGARH:**  
Joshi Autozone: 0172-5050500  
Panjab Motors: 0172-4290000

**DEHRADUN:**  
Berkeley Motors: 0135-3054000

**DELHI:**  
T & T Motors, Mohan Co-operative,  
Mathura Road: 011-66574300/330  
Rajouri Garden: 011-66574400/430

**GHAZIABAD:**  
Silver Arrows: 0-9718200500

**GURGAON:**  
T & T Motors: 0124-4263060/62

**JAIPUR:**  
T & T Motors: 0141-4300000/05

**JAMSHEDPUR:**  
Tristar Motors: 0-7763815720/  
0657-6601601/02

**JALANDHAR:**  
Joshi Autozone: 0181-5004444

**KANPUR:**  
Smart Hoops: 0-8795663300

**KARNAL:**  
Berkeley Motors: 0184-3300000

**KOLKATA:**  
Benchmark Interkrafts: 1800 3000 3310

**LUCKNOW:**  
Smart Hoops: 0522-6004008/9

**LUDHIANA:**  
Joshi Autozone: 0161-5055000

**MOHALI:**  
Panjab Motors: 0172-4290000

**NOIDA:**  
Silver Arrows: 0-9999200500

### WEST:

**AHMEDABAD:**  
Benchmark Cars: 0-9377662000

**AURANGABAD:**  
B. U. Bhandari: 0-8605121333/  
0240-6452601/02

**BHOPAL:**  
Benchmark Cars: 0-9098233233

**GOA:**  
Counto Motors: 0832-2415122

**INDORE:**  
Benchmark Cars: 1800-3000-8844

**KOLHAPUR:**  
B. U. Bhandari: 0231-2661422/  
0-8380093555

**MUMBAI:**  
Auto Hangar, Prabhadevi: 022-67434362/63  
Auto Hangar, Andheri: 022-67106660/61

**Metro Motors, Auto Hangar division**  
Hughes Road: 022-66123500/11

**Shaman Wheels, Off BKC:** 022-24228787

**NAVI MUMBAI:**  
Shaman Wheels: 022-24228787

**NAGPUR:**  
Auto Hangar: 0-9223540191/  
07104-238180/1/2/3

**NASHIK:**  
Indisch Motoren: 0253-6645555

**PUNE:**  
B. U. Bhandari, Baner: 020-67212129  
B. U. Bhandari, Bund Garden: 020-67212131  
Trinity Motors: 020-67342525

**RAJKOT:**  
Benchmark Cars: 0-9377750050

**RAIPUR:**  
Auto Hangar: 0771-6537801/0-8518887155

**SURAT:**  
Benchmark Cars: 0-9377660066

**VADODARA:**  
Benchmark Cars: 0-9377390001

### SOUTH:

**BENGALURU:**  
Sundaram Motors: 080-22070720/21

**Akshaya Motors, Mysore Road:**  
080-22966300, 0-9066030989

**Akshaya Motors, Koramangala:**  
080-22966296, 0-9019326026

**CALICUT:**  
Bridgeway Motors: 0495-30 55555

**CHENNAI:**  
Trans Car: 044-40200300

**Titanium Motors:** 044-66498080/8181/8282

**COIMBATORE:**  
Sundaram Motors: 0422-2452020

**COCHIN:**  
Rajasree Motors:  
0484-2706332/2706432/2706134  
2607027/37/47

**HYDERABAD:**  
Mahavir Motors: 040-43403004

**MADURAI:**  
Sundaram Motors: 0452-2320433/  
0-9500966946

**MANGALORE:**  
Sundaram Motors: 0824-2214833/2215833/  
0-9008442155

**TRIVANDRUM:**  
Rajasree Motors: 0471-2380377/  
0-9846547551

**VIJAYAWADA:**  
Mahavir Motors: 0866-2082559/  
0-9885303004

## MERCEDES-BENZ CERTIFIED:

**AHMEDABAD:**  
Benchmark Cars: 0-9016665000

**BENGALURU:**  
Akshaya Motors: 0-9019944044

**Sundaram Motors:** 080-22070746/  
0-9880662051

**CHANDIGARH:**  
Joshi Autozone: 0-9878941930/  
0172-5050500/510

**CHENNAI:**  
Transcar: 0-9841049994

**COIMBATORE:**  
Sundaram Motors: 0422-2452020

**DELHI:**  
T&T Motors, Mathura Road: 0-9711774424  
T&T Motors, West Delhi: 0-9711112243

**GHAZIABAD:**  
Silver Arrows: 0-9718200500

**HYDERABAD:**  
Adishwar: 0-7799633004

**INDORE:**  
Benchmark Cars: 0731-6675520

**KOCHI:**  
Rajasree Motors: 0-9846547311

**LUCKNOW:**  
Smart Hoops: 0522-6004009

**MOHALI:**  
Panjab Motors: 0172-4290000

**MUMBAI:**  
Autohangar India: 0-9223546204,  
0-9223547099

**Shaman Wheels:** 0-9619023450/  
022-69543333

**PUNE:**  
B U Bhandari: 020-67212172/0-8605118555

## AMG PERFORMANCE CENTERS:

**BENGALURU:**  
Sundaram Motors: 080-22070720/21

**DELHI:**  
T&T Motors: 011-66574309

**HYDERABAD:**  
Mahavir Motors: 0-9885033004/  
0-9885653004

**MUMBAI:**  
Auto Hangar: 022-67434360/61/65

**PUNE:**  
B.U. Bhandari: 020-67212131/0-8554055555

**Our national toll-free no.:**

**1800 102 9222**

**One Call. All Answers.**

**For a complete list of Mercedes-Benz outlets, please explore the dealer locator tab on [www.mercedes-benz.co.in](http://www.mercedes-benz.co.in)**

**Mercedes-Benz India Private Limited:** E-3, MIDC Chakan - Phase III, Chakan Industrial Area, Kuruli & Nighoje, Tal: Khed, Pune - 410 501 (India)  
Toll free No.: 1800 102 9222. e-mail: customerconnect@daimler.com, **website: [www.mercedes-benz.co.in](http://www.mercedes-benz.co.in)**

**Please note:** This brochure is intended for general information, description and illustration of the Product including optional functions and equipment and may not be specific to a Product since specification of a product may change from time to time. Optional features, functions and equipment etc. may not be present in the Standard or Variant Product or Special Edition Product. Further, Standard specifications of a product may also vary from time to time. Colours may differ from those shown in pictures in the brochure, owing to printing. Mercedes-Benz India reserves the right to make changes, at any point of time, without prior notice, in design, colours, materials, components, equipment, specifications, features, functions, make and models etc. The information given in this brochure shall be regarded as accurate at the time of going to print and may vary thereafter due to any developments or any other reason. Interested parties should confirm with the Authorised Dealer about the correct specification of the product they desire to purchase. For the latest authentic information and updates, kindly contact your nearest Authorised Dealer.

All title, ownership rights and intellectual property rights in and relating to this brochure / magazine or publication material or any copies thereof including but not limited to copyright, logos, names, trademarks, service marks, design, text, images, links, concepts and themes are owned by Daimler AG and/or its subsidiaries collectively or used under authorised license by the Daimler AG. Any reproduction, transmission, publication, performance, broadcast, alteration, license, creation of derivative works or other use in whole or in part in any manner without the prior written consent of the Daimler AG is strictly prohibited.

Month of going to press: May, 2016. Mercedes-Benz cars: The GLC meets Bharat Stage IV equivalent emission norms.

CIN - U34102PN1994PTC083160